

## SERVICE INSTRUCTION

# Introduction of a radiator retrofit kit part no. 881535 for the new radiator part no. 997083 on ROTAX® Engine Type 912 i, 912 and 914 (Series)

ATA System: 75-00-00 Cooling system

### OPTIONAL

#### 1) Planning information

To obtain satisfactory results, procedures specified in this publication must be accomplished with accepted methods and prevailing legal regulations.

BRP-Powertrain GmbH & Co KG. cannot accept any responsibility for the quality of work performed in accomplishing the requirements of this publication.

##### 1.1) Applicability

All engines of type 912 i /912/914 Series which have to be equipped with the radiator retrofit kit packaged (part no. 881535) and/or, depending on the installation situation of the radiator part no. 997083, have to be retrofitted with one of these kits.

##### 1.2) Concurrent ASB/SB/SI and SL

None.

##### 1.3) Reason

In the course of continuous development, a new radiator (part no. 997083) has been introduced. Because the radiator has a changed outside contour and dimension changes, a radiator retrofit kit, has been created, which should be used in installation situations where a rectangular mounting is needed. For this purpose, corresponding cover plates have to be riveted onto the radiator.

##### 1.4) Subject

Introduction of a radiator retrofit kit part no. 881535 for the new radiator part no. 997083 on ROTAX® Engine Type 912 i, 912 and 914 (Series).

##### 1.5) Compliance

NONE - For Information Only.



Non-compliance with these instructions could result in engine damages, personal injuries or death.

##### 1.6) Approval

The technical content of this document is approved under the authority of DOA ref. EASA.21J.048.

## SERVICE INSTRUCTION

---

### 1.7) Labor time

Estimated labor time:

engine installed in the aircraft - - - labor time will depend on installation and therefore no estimate is available from the engine manufacturer.

### 1.8) Mass data

change of weight - - none.

moment of inertia - - unaffected.

### 1.9) Electrical load data

No change.

### 1.10) Software modifications

No change.

### 1.11) References

In addition to this technical information refer to current issue of

- Operators Manual (OM)
- Engine data sheet
- Illustrated Parts Catalog (IPC)
- Installation Manual (IM)
- Maintenance Manual (MM)

NOTE: The status of the Manuals can be determined by checking the table of amendments. The 1<sup>st</sup> column of this table shows the revision status. Compare this number to the are listed on the ROTAX WebSite: [www.FLYROTAX.com](http://www.FLYROTAX.com). Updates and current revisions can be downloaded for free.

### 1.12) Other Publications affected

None.

### 1.13) Interchangeability of parts

- All parts are interchangeable without limitation

# SERVICE INSTRUCTION

## 2) Material Information

### 2.1) Material- cost and availability

Price and availability will be provided on request by ROTAX® Authorized Distributors or their Service Centers.

### 2.2) Company support information

- Any possible support by BRP-Powertrain will be provided on request by ROTAX® Authorized Distributors or their Service Centers.

### 2.3) Material requirement per engine

parts requirement:

New p/n	Qty/ engine	Description	Old p/n	Application
881535	1	Radiator retrofit kit	-	Engine type 912 i/912/914 Series
consists of:				
n.a.	2	Cover plate	-	
n.a.	10	Riveted bolt Ø4 mm	-	

### 2.4) Material requirement per spare part

None.

### 2.5) Rework of parts

None.

### 2.6) Special tooling/lubricant-/adhesives-/sealing compound-price and availability

Price and availability.

Price and availability will be provided on request by ROTAX® Authorized Distributors or their Service Centers:

Description	Qty/engine	Part no.	Application
Metal drill Ø4,1 mm	1	n.a.	Radiator retrofit kit
Screw driver	1	n.a.	Radiator retrofit kit
Riveting tongs	1	n.a.	Radiator retrofit kit

#### NOTICE

When using these special tools observe the manufacturers specifications.

# SERVICE INSTRUCTION

## 3) Accomplishment/Instructions

**NOTE:** Before accomplishment, review the entire document to make sure you have a complete understanding of the procedure and requirements.

### Accomplishment

All measures must be implemented and confirmed by at least one of the following persons or organizations:

- Persons with approved qualifications for the corresponding engine types.

**NOTE:** All work has to be performed in accordance with the relevant Maintenance Manual.

### Safety notice



#### **WARNING**

Identifies an instruction which, if not followed, may cause serious injury or even fatal injury.



#### **CAUTION**

Identifies an instruction which, if not followed, may cause minor or moderate injury.

#### **NOTICE**

Identifies an instruction which if not followed, may severely damage the engine or could lead to suspension of warranty.

### **ENVIRONMENTAL NOTE**

Environmental notes give you tips on environmental protection.

#### **3.1) Requirements for installation**

See Fig. 1.

In the course of continuous development, a new radiator (part no. 997083) has been introduced. Because the radiator has a changed outside contour and dimension changes, a radiator retrofit kit, (part no. 881535) has been created, which should be used in installation situations where a rectangular mounting is needed. For this purpose, corresponding cover plates have to be riveted onto the radiator.

#### **3.2) Requirements for maintenance**

See current issue of Maintenance Manual (Line), Chapter: Maintenance checklist.

In addition to the radiator also check the riveting and cover plates.

# SERVICE INSTRUCTION

## 3.2.1) Installation of the cover plates

See Fig. 1.

Following steps are necessary:

Step	Procedure
1	Enlarge the holes of the radiator (1), using a suitable screw driver (2). Tilt the fins slightly to the side.
2	If necessary use a metal drill $\varnothing 4.1$ mm (3) to rebore the holes of the radiator and the cover plates (4).
3	Install the cover plates and observe the correct mounting position.
4	During the riveting process apply some force to the rivets (5), so that they are pushed into the holes. Reposition the riveting tongs accordingly.

- Restore aircraft to original operating configuration.
- Connect negative terminal of aircraft battery.

## 3.3) Test run

Conduct test run including ignition check and leakage test.

## 3.4) Summary

These instructions (section 3) have to be carried out in accordance with the deadlines specified in section 1.5.



A revision bar outside of the page margin indicates a change to text or graphic.

Approval of translation to best knowledge and judgement-in any case the original text in German language and the metric units are authoritative.

## 3.5) Enquiries

Enquiries regarding this Service Instruction should be sent to the ROTAX® authorized distributor of your area.

A list of all distributors is provided on [www.FLYROTAX.com](http://www.FLYROTAX.com).

## SERVICE INSTRUCTION

### 4) Appendix

The following drawings should provide additional information:

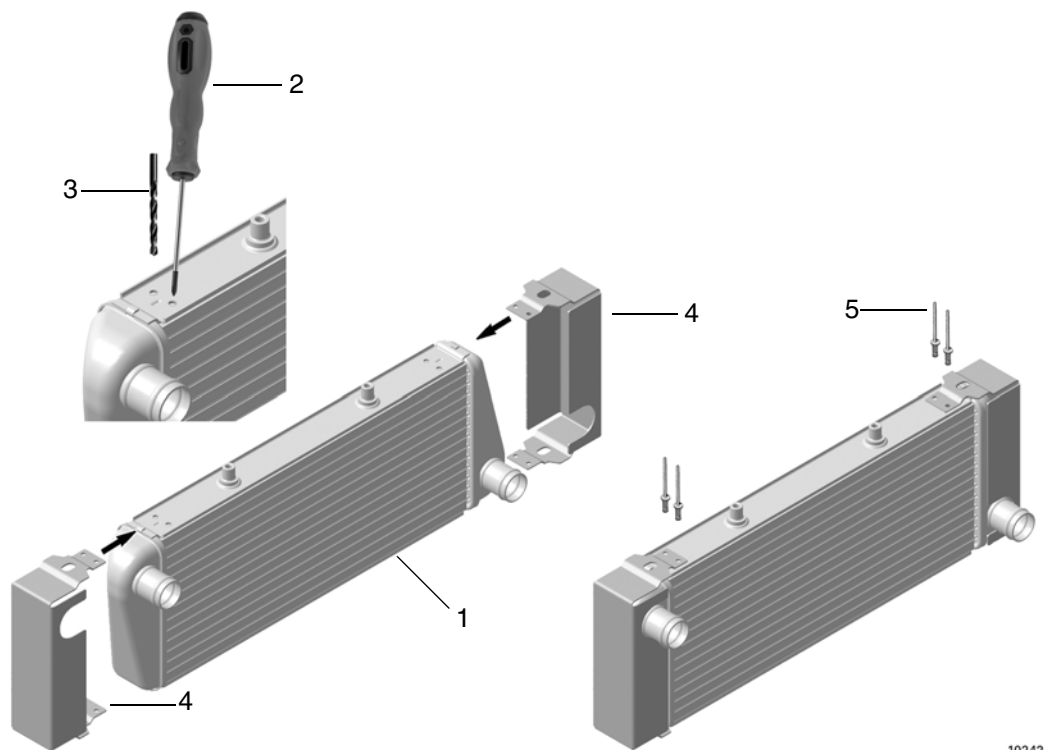

10242

- 1 Radiator
- 2 Screw driver
- 3 Metal drill Ø4.1mm
- 4 Cover plates
- 5 Rivet

Fig. 1  
Radiator retrofit kit

NOTE: The illustrations in this document show the typical construction. They may not represent full detail or the exact shape of the parts which have the same or similar function.

Exploded views are **no technical drawings** and shall be used for reference purposes only. For specific detail, refer to the current documents of the respective engine type.

d06196.fm